

DOOR CLOSER ADJUSTMENT

CLOSING CYCLE

NOTE: CLOSING arcs (CLOSE and LATCH) are controlled two (2) separate speed adjusting valves. adjust the CLOSING speed first, then adjust the LATCHING speed.

- CLOSING speed adjustment is accomplished by full rotations of the speed adjusting valve.
 - Turn the speed adjustment valve **CLOCKWISE** for a **SLOWER CLOSE** arc closing speed.
 - Turn the speed adjustment valve **COUNTER-CLOCKWISE** for a **FASTER CLOSER** arc closing speed.
- LATCH speed adjustments is accomplished by full rotations of the speed adjusting valve.
 - Turn the speed adjustment screw **CLOCKWISE** for a **SLOWER LATCH** arc closing speed.
 - Turn the speed adjustment screw **COUNTER-CLOCKWISE** for a **FASTER LATCH** arc closing speed.

CAUTIONS!

Do not turn speed adjusting valve more than two (2) full turns counter-clockwise from its factory set position, as two speed adjusting valves could become dislodged from the door closer body, resulting in the loss of internal fluid and failure of the device.

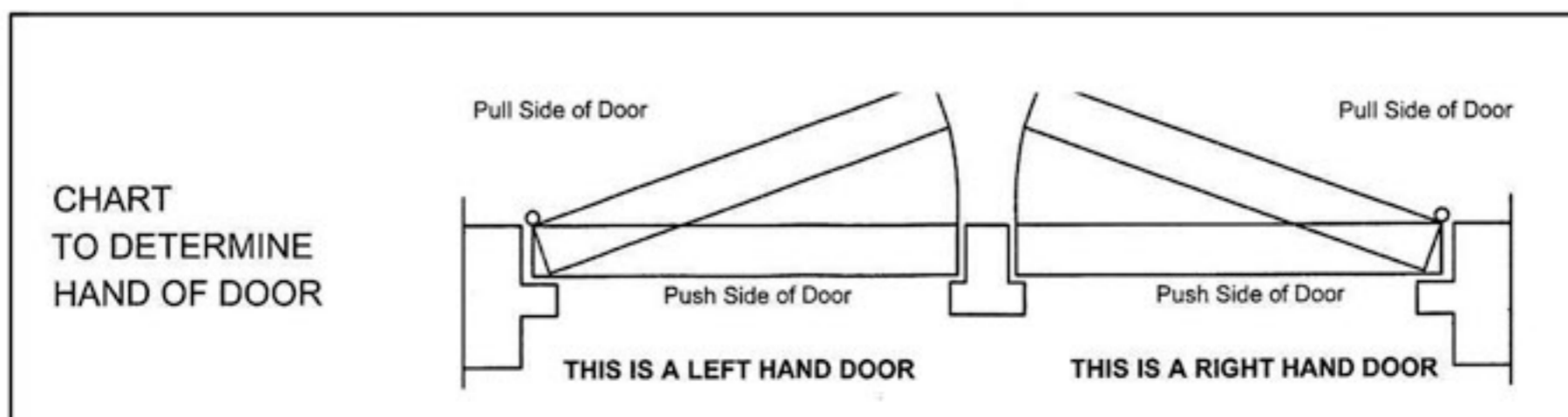
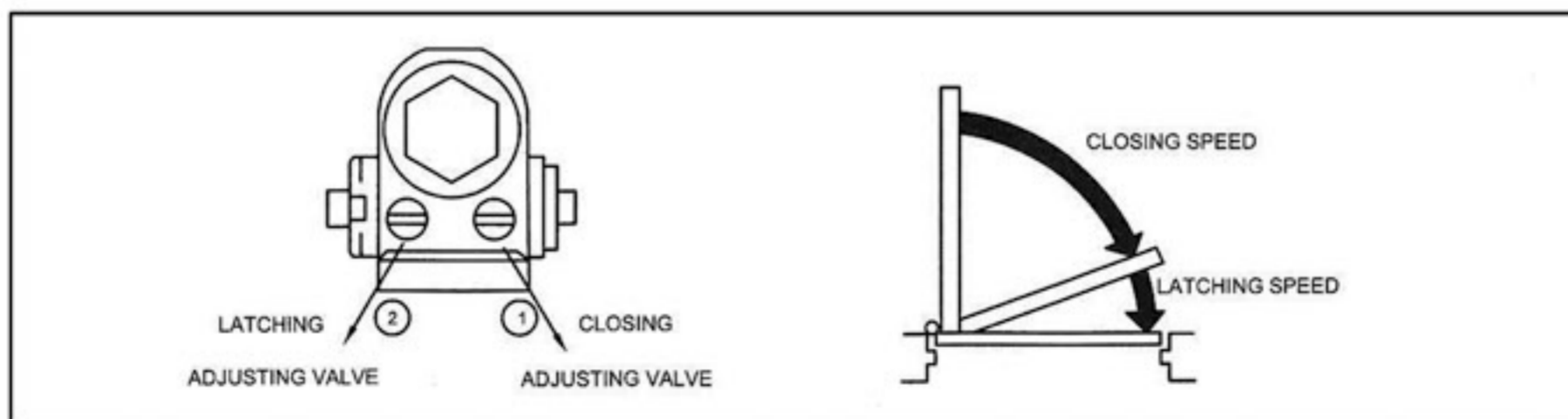

Installation instructions for REGULAR ARM (PULL SIDE) Mounting

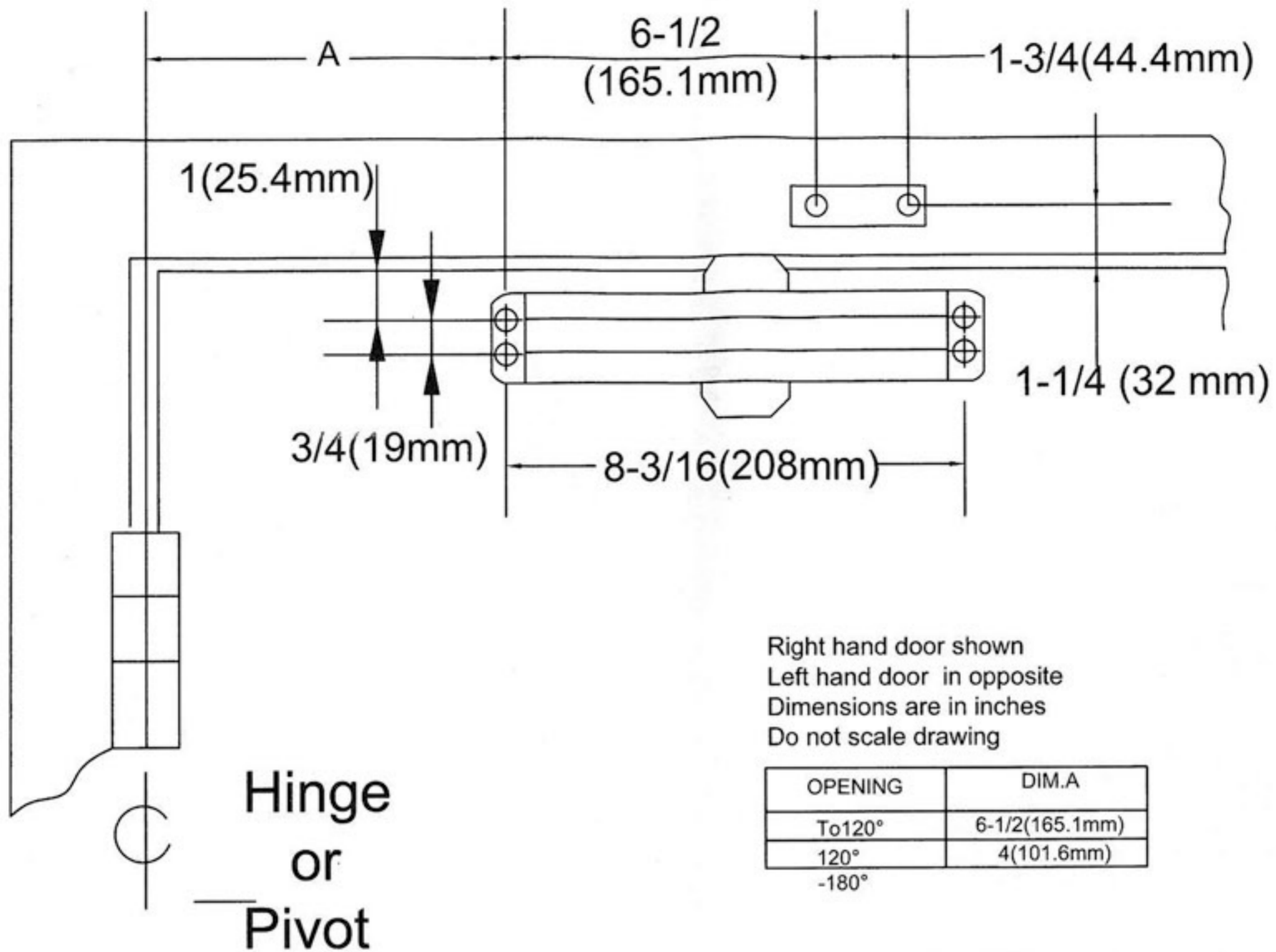

INSTALLATION INSTRUCTONS

1. Select door opening and use dimensions shown above, mark four (4) holes on door for door closer and two (2) holes on frame for arm shoe.
2. Drill pilot holes in door and frame for # 14 all-purpose screws or drill or tap for 1/4-20 machine screw.
3. Install forearm/arm shoe assembly to door using screws provided.
4. Mount closer on frame using screw provided. SPEED ADJUSTING VALVE MUST BE POSITIONED TOWARD HINGE EDGE.
5. Install main arm to top pinion shaft, perpendicular to door as shown below. Secure tightly with arm screw/washer assmebly provided.
6. Adjust length of forearm so that forearm is perpendicular to frame when assmebled to preloaded main arm (illustration below). Secure forearm to main arm with screw /washer assembly provided.
7. Snap pinion cap over shaft at bottom of closer.
8. Adjust closing speed of door. following instructions as shown page 1.

OPEN CYCLE

NOTED:

These instructions apply to closers equipped with backcheck.
To increase backcheck intensity, turn valve marked "BC" clockwise.
To decrease backcheck intensity, turn valve marked BC counter-clockwise

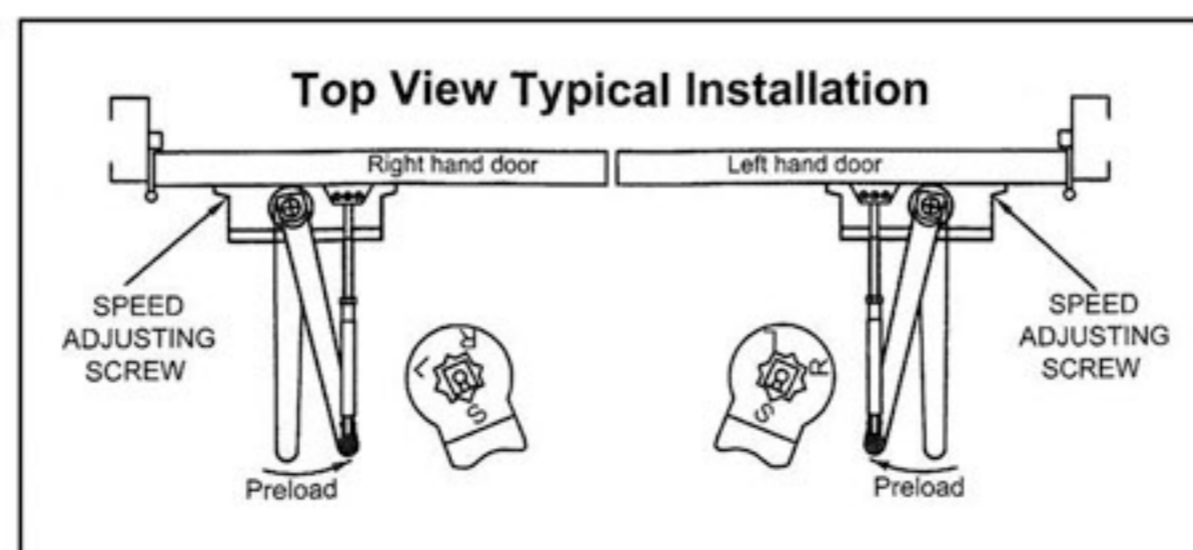
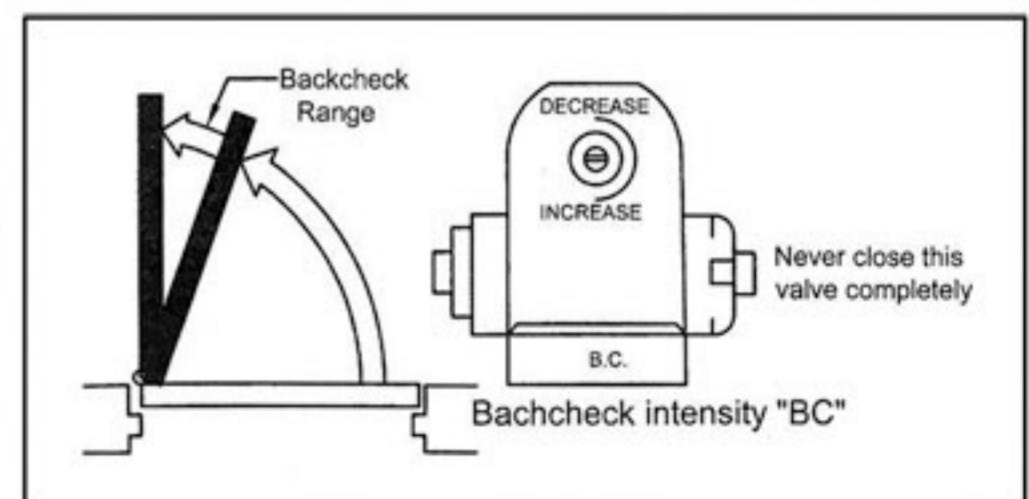

Installation instructions for TOP JAMB (PUSH SIDE) Mounting

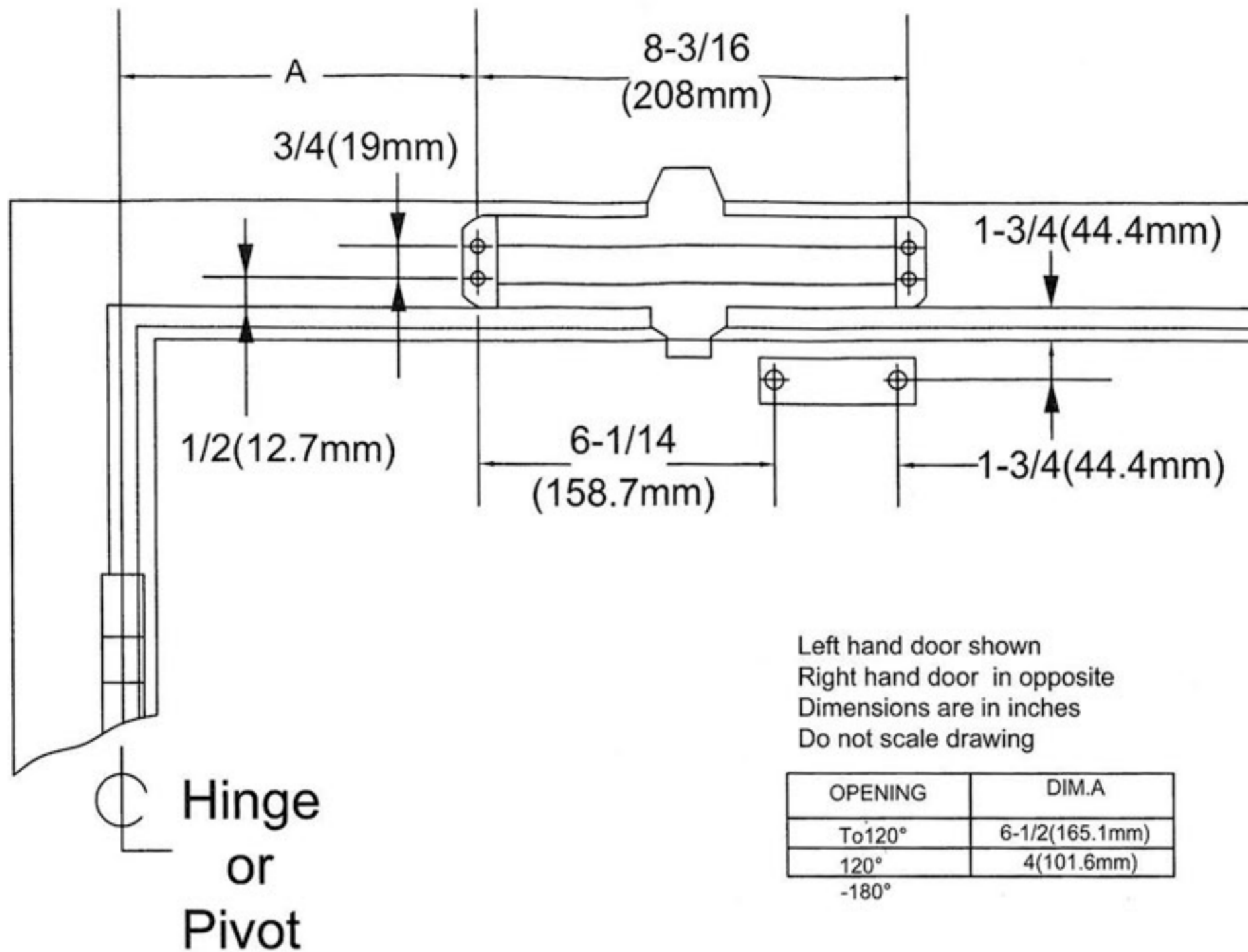

OPENING	DIM.A
To 120°	6-1/2 (165.1mm)
120° -180°	4 (101.6mm)

INSTALLATION INSTRUCTONS

1. Select door opening and use dimensions shown above, mark four (4) holes on frame for door closer and two (2) holes on door for arm shoe.
2. Drill pilot holes in door and frame for # 14 all-purpose screws or drill or tap for 1/4-20 machine screw.
3. Install forearm/arm shoe assembly to door using screws provided.
4. Mount closer on frame using screw provided. SPEED ADJUSTING VALVE MUST BE POSITIONED TOWARD HINGE EDGE.
5. Install main arm to top pinion shaft, perpendicular to frame as show. Secure tightly with screw/washer assmebly provided.
6. Adjust length of forearm so that forearm is perpendicular to frame when assmebled to preloaded main arm (illustration below). Secure forearm to main arm with screw /washer assembly provided.
7. Snap pinion cap over shaft at bottom of closer.
8. Adjust closing speed of door. following instructions as shown page 1.

OPEN CYCLE

NOTED:
These instructions apply to closers equipped with backcheck.
To increase backcheck intensity, turn valve marked "BC" clockwise.
To decrease backcheck intensity, turn valve marked BC counter-clockwise

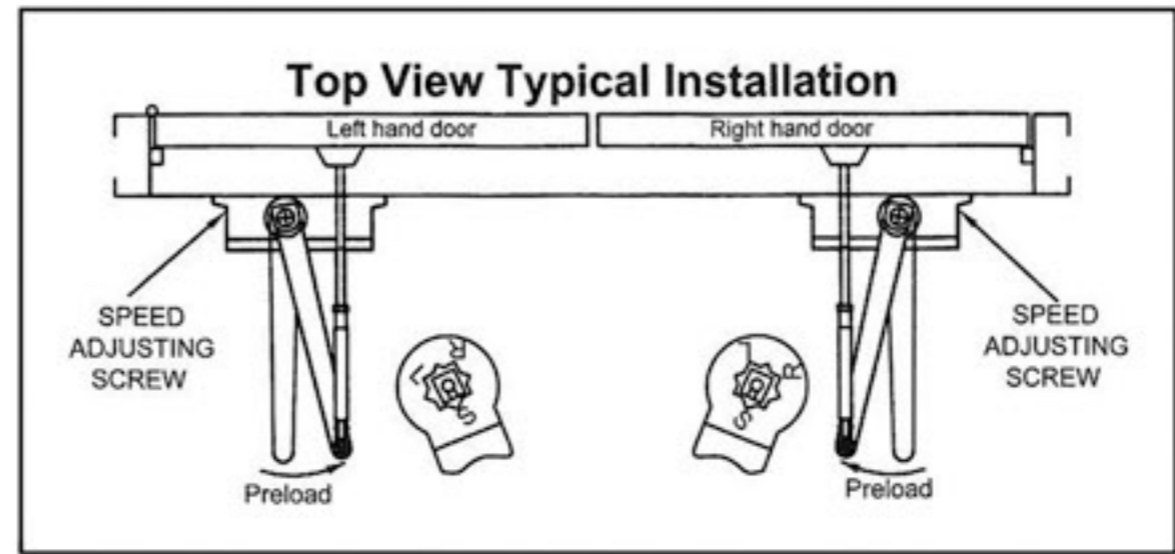
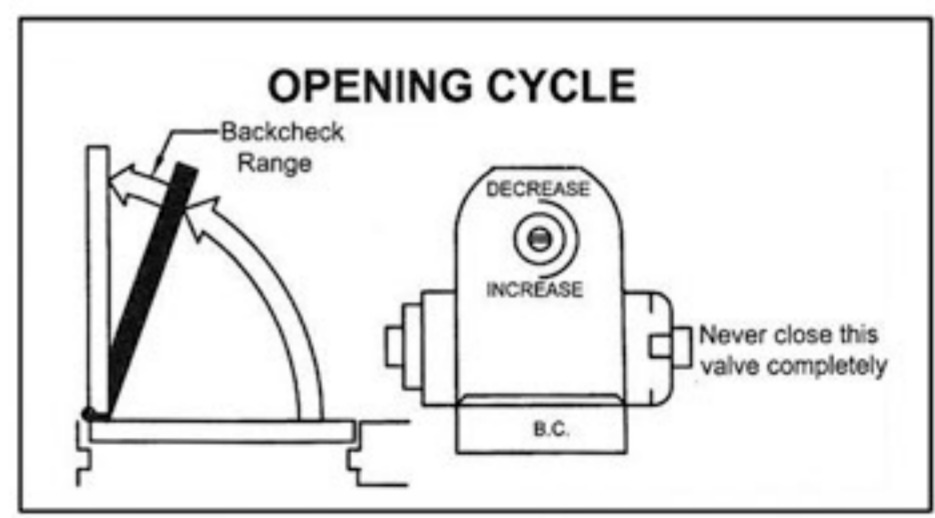

Installation Instructions for PARALLEL ARM (PUSH SIDE) Mounting

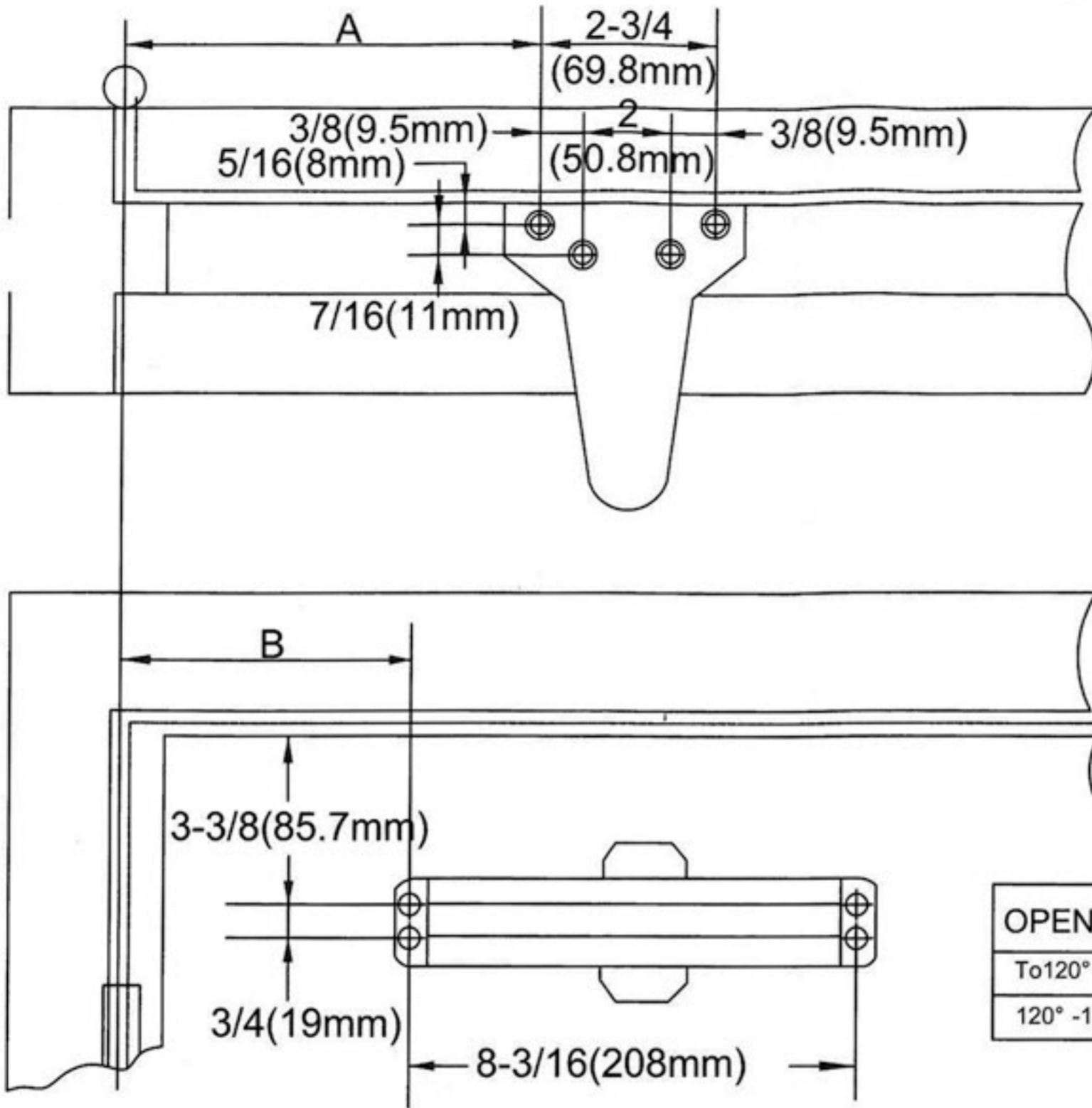

Left hand door shown
Right hand door in opposite
Dimensions are in inches
Do not scale drawing

OPENING	DIM.A	DIM.B
To 120°	10-3/4(273mm)	7-13/16(198.4mm)
120° -180°	8-3/4(222.2mm)	5-5/8(142.9mm)

INSTALLATION INSTRUCTONS

1. Select door opening and use dimensions shown above, mark four (4) holes on door for closer body and four (4) holes underside of frame for parallel bracket.
2. Drill pilot holes in door and frame for # 14 all-purpose screws or drill or tap for 1/4-20 machine screw.
3. Mount closer on door using screw provided. SPEED ADJUSTING VALVE MUST BE POSITIONED BACK HINGE EDGE.
4. Using a wrench on the square shaft at bottom of closer, rotate shaft approximately 45 angle towards hing edge of door. Hold and place main arm shaft on top of closer at proper index mark as illustrated. FOR LEFT HAND DOOR "L" (Illustration "A"). FOR RIGHT HAND DOOR "R" (Illustration "B"). Tighten arm screw with lockwasher securely.
5. Remove arm shoe from forearm and discard. Install ROD end of forearm to P.A bracket using screw/washer assembly provided.
6. Adjust length of for adjustable forearm so that it is parallel to frame.
7. Adjust closing speed of door. following instructions as shown page 1.

OPEN CYCLE

NOTED:

These instructions apply to closers equipped with backcheck.
To increase backcheck intensity, turn valve marked "BC" clockwise.
To decrease backcheck intensity, turn valve marked BC counter-clockwise

