

Global TH1100-HK1 - Commercial Aluminum Full Surface Hinge, Pair

REPLACEMENT HINGES

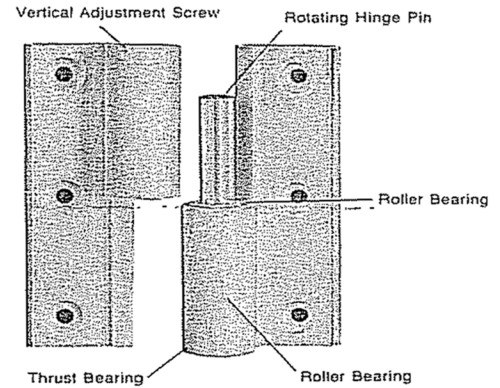
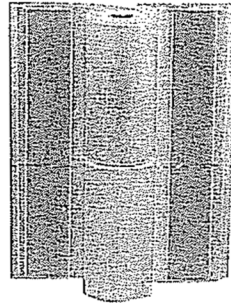
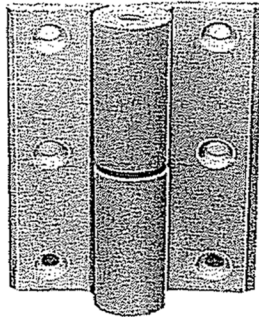

For **FLUSH** or **1/8" OFFSET DOORS**

ONE DELUXE HINGE KIT

CONTAINS

- 2 Roto Pin Hinges**
- 12 One-Way Screws**
- 4 Cover Strips**

CAN BE SUCCESSFULLY USED ON ALL TYPES OF COMMERCIAL DOORS & FRAMES UP TO 500 POUNDS.

Quick and Easy to Install

- A. Remove old hinges
- B. Place Door into opening. Be sure to allow for proper clearance all around the door.
- C. - FOR 1/8" OFFSET DOOR INSTALLATION:
Do NOT use Shim. There is a 1/8" offset built into these hinges. Lay one hinge into place so hinge adjustment screw **MUST** face **UP** on **TOP** hinge and **DOWN** on **BOTTOM** hinge
- FOR FLUSH DOOR INSTALLATION:
Please use Shim. Lay one hinge into place with shim placed underneath the 1/8" offset leaf - but **ALWAYS** - on **JAMB**. Position of adjustment screw **MUST** face **UP** on **TOP** hinge and **DOWN** on **BOTTOM** hinge.
- D. Use the hinge set as a template (do not take apart) and align center of barrel over center of gap, mark only center hole on each leaf
- E. Drill 15/64" diameter hole through jamb on each mark
- F. Use special burglar-proof self tapping screws
- G. Once hinges are set, drill the remaining 15/64" holes in each hinge leaf.
- H. Peel away the backing from the Cover Strips and press into place

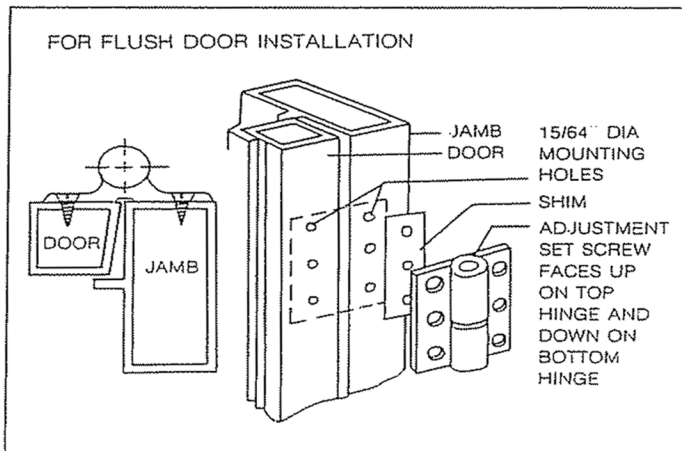
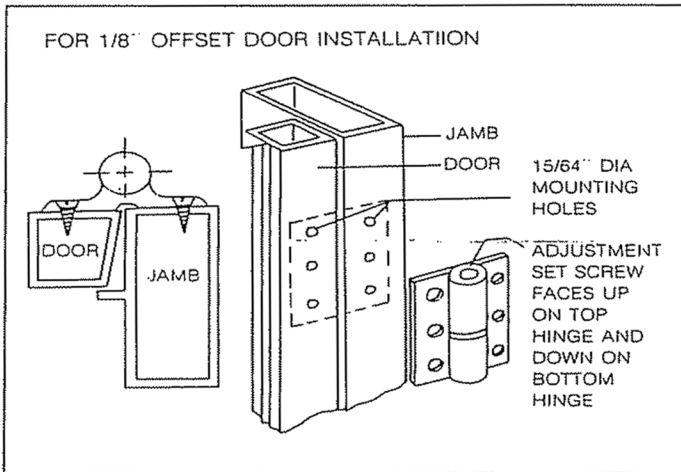

Very Important - Please Note

When hinges are properly installed, the top hinge has the adjustment screw on the top and the bottom hinge has the adjustment screw on the bottom